

# Assembly & Installation Instructions

## SORBETTI: Spanning Channel

### 1 Set-up

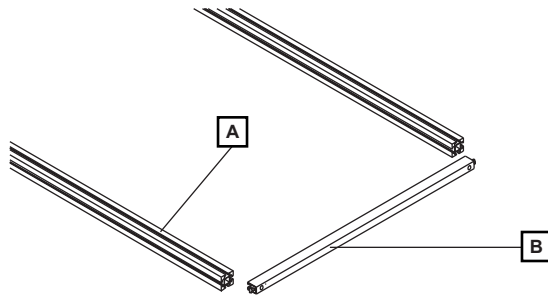

### 2 Align & Insert

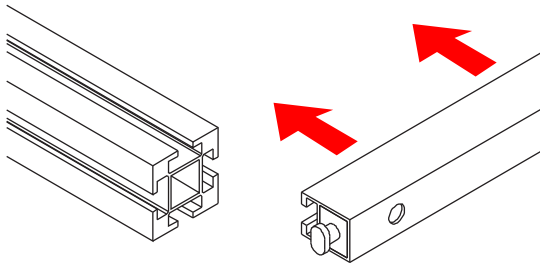

### 3 Tighten

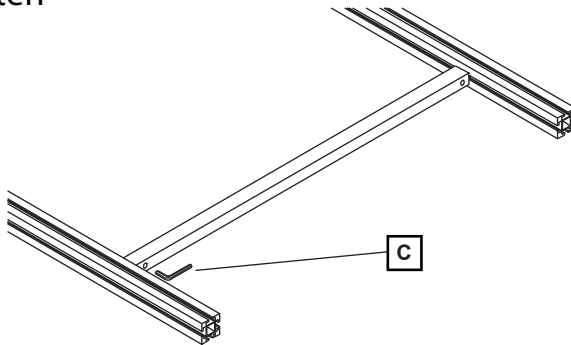

### 4 Insert panel

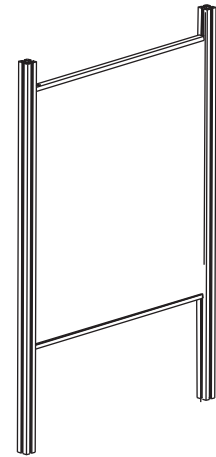
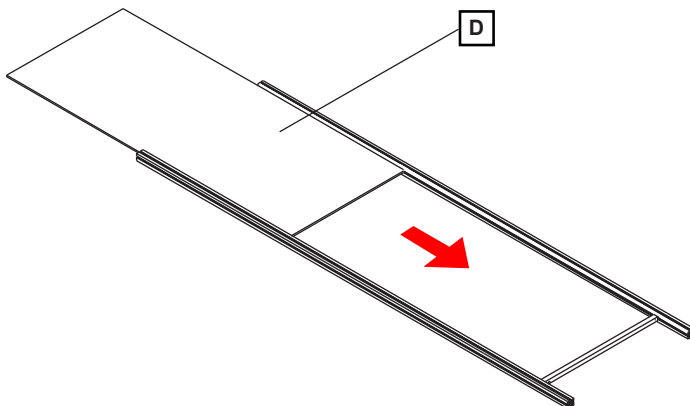

### Spanning Channel Assembly

1. Begin by laying the SORBETTI UPRIGHTS on the ground **A**

2. Next take the SPANNING CHANNEL **B** and position it so that the face with the slot is facing towards the extrusions.

Slide the SPANNING CHANNEL **B** into the upright channels.

3. Once in position, tighten in place using the provided allen key **C**. Be sure to tighten both ends of the SPANNING CHANNEL.

4. Slide ACRYLIC or WOOD PANEL **D** into the extrusion from the opposite end.

5. Slide the 2nd SPANNING CHANNEL into the SORBETTI UPRIGHT, capping off the remaining side of the PANEL.



B&N INDUSTRIES  
650.593.4127  
WWW.BNIND.COM